

Heavy Duty Multi Purpose Roller DR1000



Option :

- Designed to suit standard commercial applications for 50kg per roller carriage
- Materials outer carriage for engineered polymer, Inner carriage cast zinc passivated
- Cycle rating 30,000

Features :

- Suits Aluminum and UPVC sliding doors.
- Full adjustable carriage gives 10mm height adjustment.
- Outer carriage and internal assembly manufactured to withstand corrosive environments
- High performance roller with “ZZ” bearing and dust seal
- ZZ bearing with ground precision for corrosion free operation.
- Recommended for larger sliding doors up to 100 kg.

Certified by



| Model | Application | Max. Weight per roller | Finish | Product Number |
|--------|-------------|------------------------|--------|-----------------------------|
| DR1000 | Sliding | 50kgs | Black | Please refer to below table |

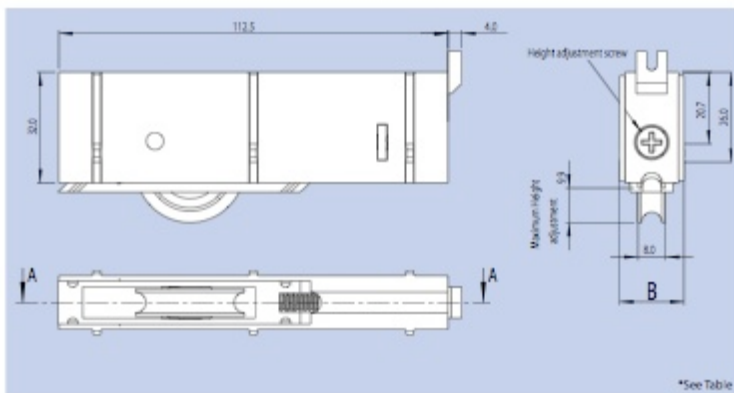

Standard Widths Available

| Part No. | “B” Size |
|------------|----------|
| DR 1001/71 | 18.5 mm |
| DR 1002/71 | 18 mm |
| DR 1003/71 | 18 mm |
| DR 1004/71 | 21 mm |
| DR 1005/71 | 25 mm |
| DR 1006/71 | 26.50 mm |
| DR 1007/71 | 26 mm |